



BOSCH

Akku-Winkelschleifer

GWS 18V-15 P | 3 601 JH6 A02

Inhaltsverzeichnis

Abbildung - Typ.....2

Abbildung - Typ - E

3 601 JH6 A02
 Stand } 22-05-27
 Issue } **Fig./Abb. 1**

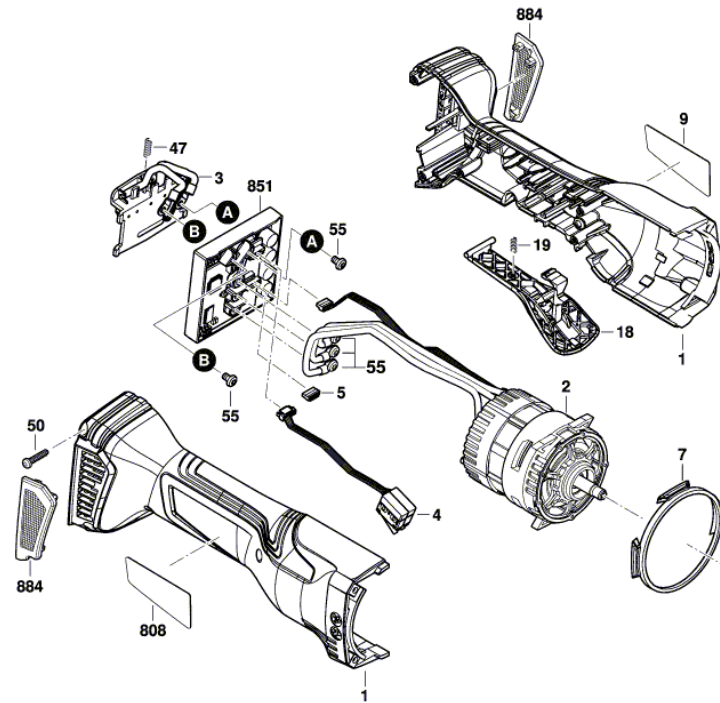

Änderungen vorbehalten
 Modifications reserved
 Modifications réservées
 Salvo modificaciones

● = Zahnspiel 0,08 - 0,25mm mit Pos. 35 eingestellt
 Tooth clearance 0.05 - 0.20mm adjusted with Pos. 35

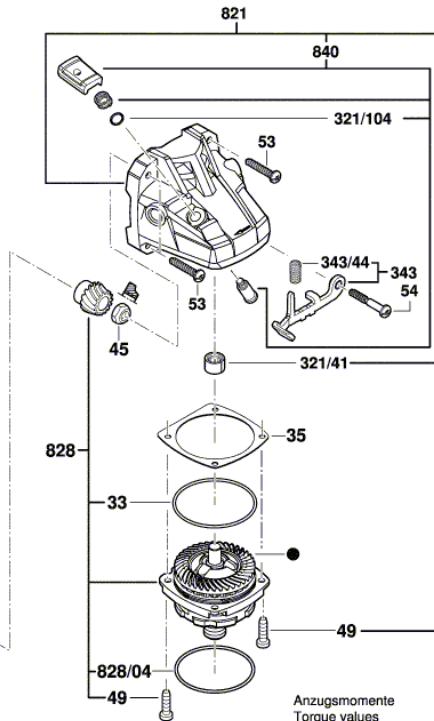

Anzugsmomente
 Torque values
 Couple de serrage
 Pares de apriete
 Pos. 45 = 8,0 - 12 Nm
 Pos. 49 = 2,6 - 3,5 Nm
 Pos. 50 = 0,8 - 1,0 Nm
 Pos. 53 = 1,5 - 1,8 Nm
 Pos. 54 = 1,5 - 1,8 Nm

Abbildung - Typ - E

3 601 JH6 A02
 Stand } 22-05-16 **Fig. /Abb. 2**
 Issue }

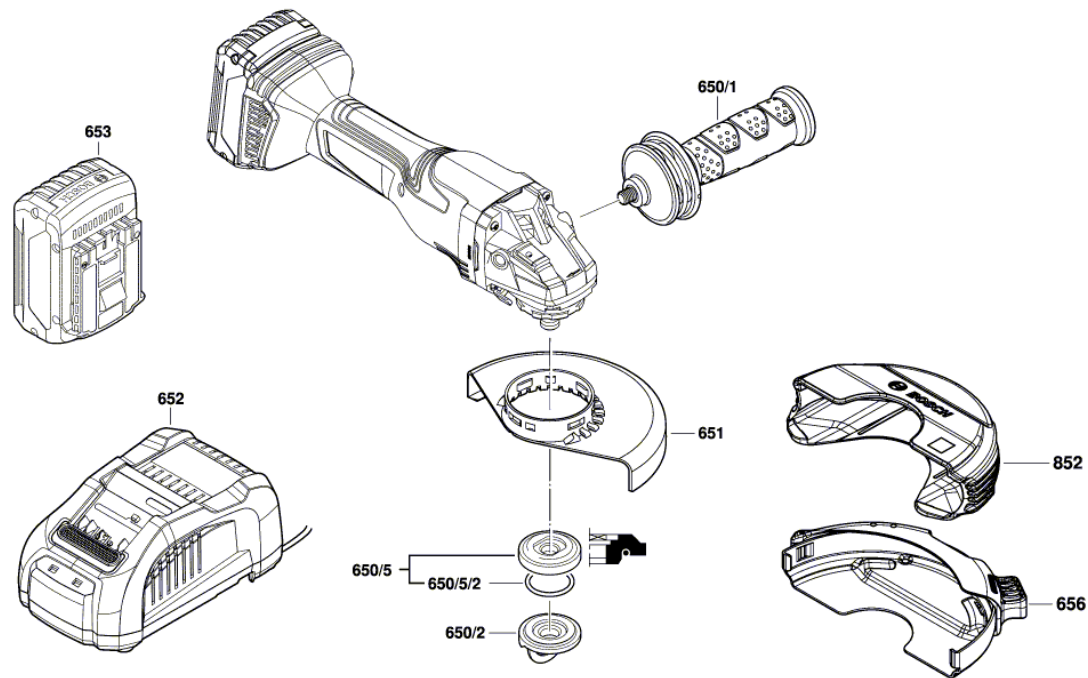

Änderungen vorbehalten
 Modifications reserved
 Modifications réservées
 Salvo modificaciones